



## **DME ProPatch Intelligent Solution**

Real-time Monitoring and Managing of connected devices made simple with seamless integration of high end intelligent physical infrastructure and abundant software functionalities



DME ProLink offers an extensive robust platform by integrating the Intelligent Infrastructure in Copper and Fiber along with the **DME ProPatch** Software to achieve the functionalities for Monitoring, Managing and Maintaining the Network infrastructure through a single portal. The platform offers the facility to define a functionality through work order for the IT Team to record and monitor the Changes within the network and offers a real time monitoring and alert to them for any unauthorized intrusion detected in the system.

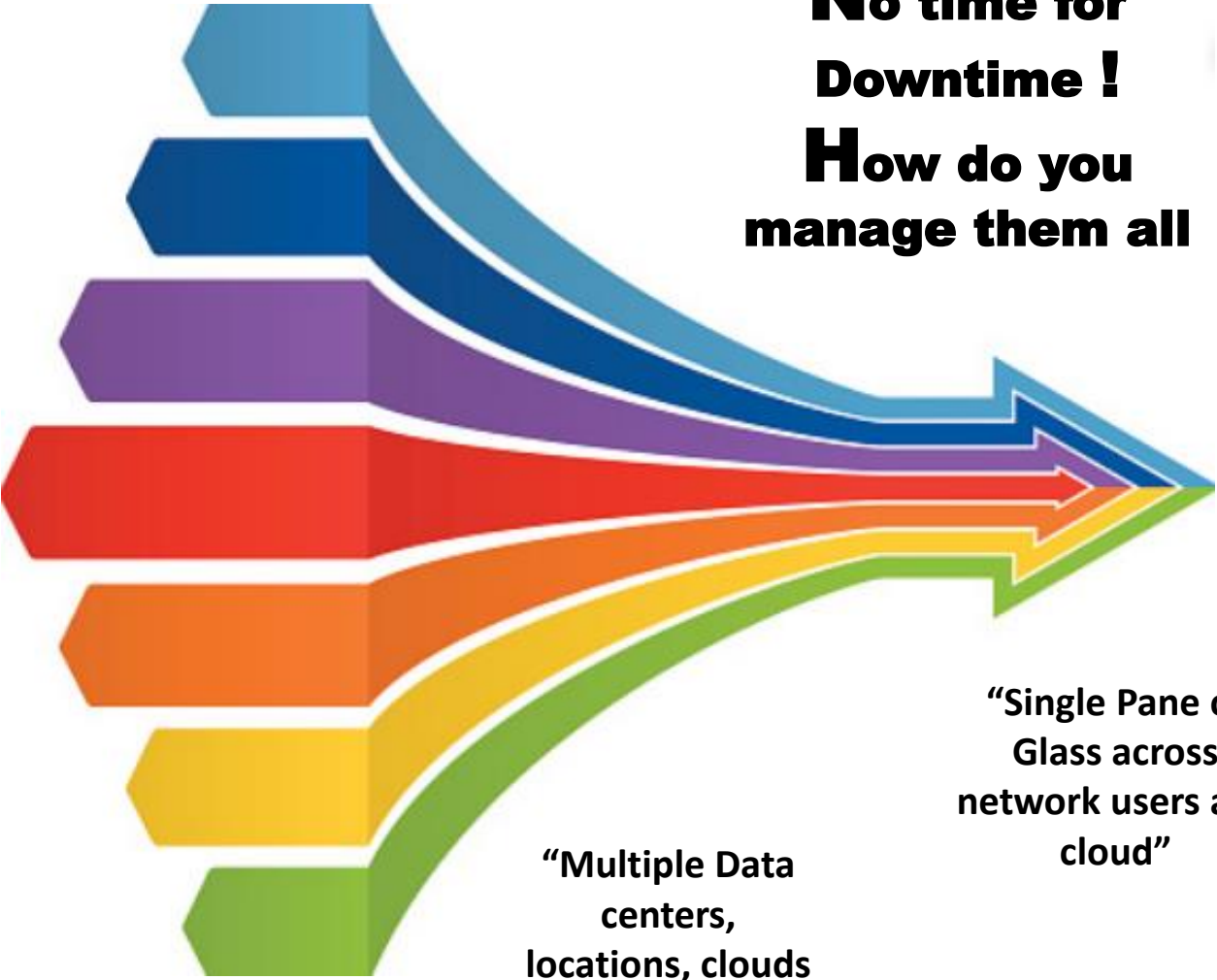

**No time for  
Downtime !  
How do you  
manage them all**

**“Multiple Data  
centers,  
locations, clouds  
& SaaS”**

**“Single Pane of  
Glass across  
network users and  
cloud”**



“DME ProPatch is a unified infrastructure and network management service portal that offers discovery, monitor, manage and billing platform through a single administrative tool”

## “Single Platform for your entire network”

“Supports entire range of cloud services and IP devices”

Real-time Monitoring – Vulnerability, validations and compliance

Patch monitoring – OS Level, Application level and network devices.

# DME ProPatch Key Capabilities



## Proactively monitor and manage assets (On premise and cloud)

Monitor your Network infrastructure (Routers, Firewalls, Access points, Switches), Microsoft Office 365 security, Google Cloud, Microsoft Azure and Amazon AWS, Cisco Stack (Meraki, Umbrella, WebEx Teams) - anytime there's a disruption or outage, notifications put you in a position to be proactive. Also supports CCTV monitoring (IP Cameras and NVRs). You can also set alerts on usage to proactively upsell clients when they're close to capacity.

## Consolidate L1 and L2 support

Reduce the complexity and time spent managing Networking gear and user accounts. With DME ProPatch software, you can efficiently manage everything from one place, and perform tasks with ease. No more training L1/L2 support teams on individual products Ease of managing passwords – no longer have to share sensitive passwords with team members or train team members across various products and portals. The alert mechanism requires a ticketing tool integration.



## Reduces non-compliance

Fully automates the Asset discovery process (on-premises or cloud)

Network documentation (topology, IP addresses)

Reminders for Renewals and Warranty

Configuration backups for business continuity

## Benefits

- Connection Monitoring
- Real Time Alert
- It is Cross-Connection Guide
- Easy Maintenance and Management
- Enables proper network visibility. Records and documents all Moves, Adds and Changes
- Meets the requirements of ANSI/TIA/EIA-606-A Standard, Class 4
- The simplicity of the system design enables users to save costs in training, management & maintenance.



## Monitoring Capabilities

Discovery of the network devices & systems and present the topology to manage. Provides the facility to perform all administrative and maintenance functions and support services that is possible remotely.

Supports Unified Network rules , manages the Networking policies across the portfolio of the devices and networks at a single click at org level using the configuration templates.

Policy Template management - Device configuration version management and adapting and configuring the devices through managed agent . it helps to check for any deviation in the configuration of the devices.

Productivity - Provide more responsive and cost-effective services to its customers.

Generates the support tickets and provides the complete range of help desk functionality and track them to closure.

Performance & Fault Monitoring charts and dashboards



# DME ProPatch software Alerts

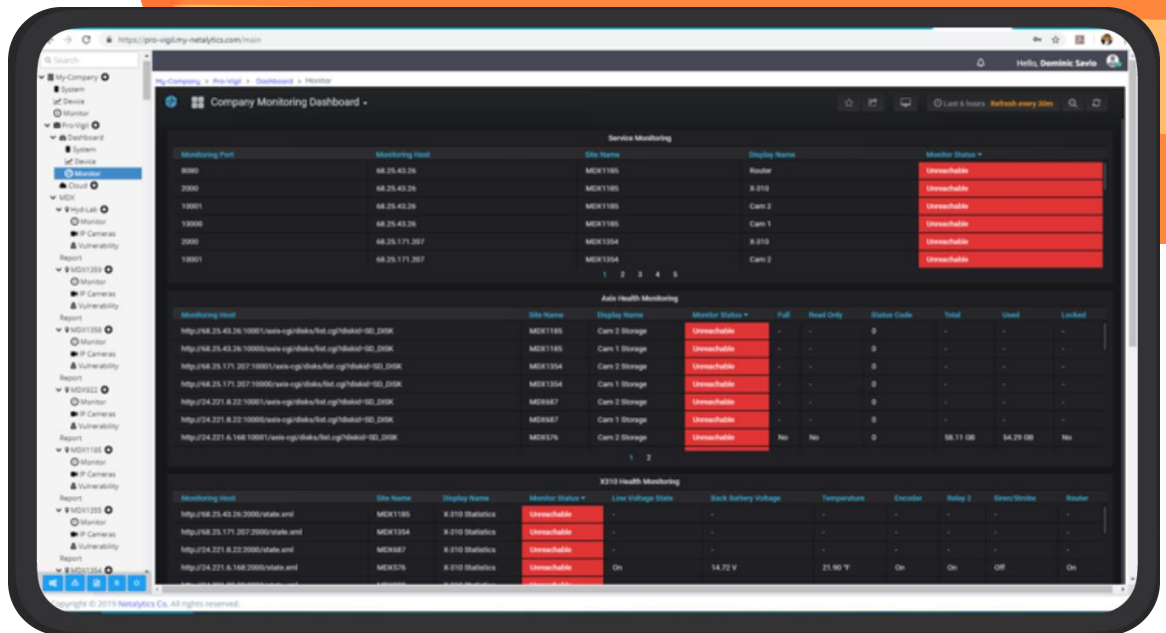

- Dynamic Thresholding and Multivariate anomaly detection
- Sequential Pattern Analysis for Incident Prediction
- Disk/Network Bandwidth Performance monitoring Analytics
- Critical thresholds based on auto learning performance setup
- Server & Switch Application Gateway monitoring
- Database services and disk utilization / log management
- Reboot / configuration
- OS /Patch / Back up monitoring
- Web Services / application servers monitoring
- Ports performance monitoring
- JVM monitoring
- Response Time & Load / CPU / Memory /Network bandwidth monitoring
- Log Analysis , log events analysis
- Monitor critical parameters of JVM like JVM CPU usage count, memory usage, GC count, GC time and thread summary
- AD monitoring

# DME ProPatch software and its Affiliates

Robust SCAP 1.2 Capabilities

OVAL, XCCDF, SCE, OCIL, CPE, CCE, CVE, Data streams, ARF

Proven support for NIST validation requirements

Supports:

- Cisco
- RedHat Linux
- Microsoft Windows
- SuSe Linux
- VMWare ESXi
- Juniper
- Apple Mac
- AIX



# Solution Architecture

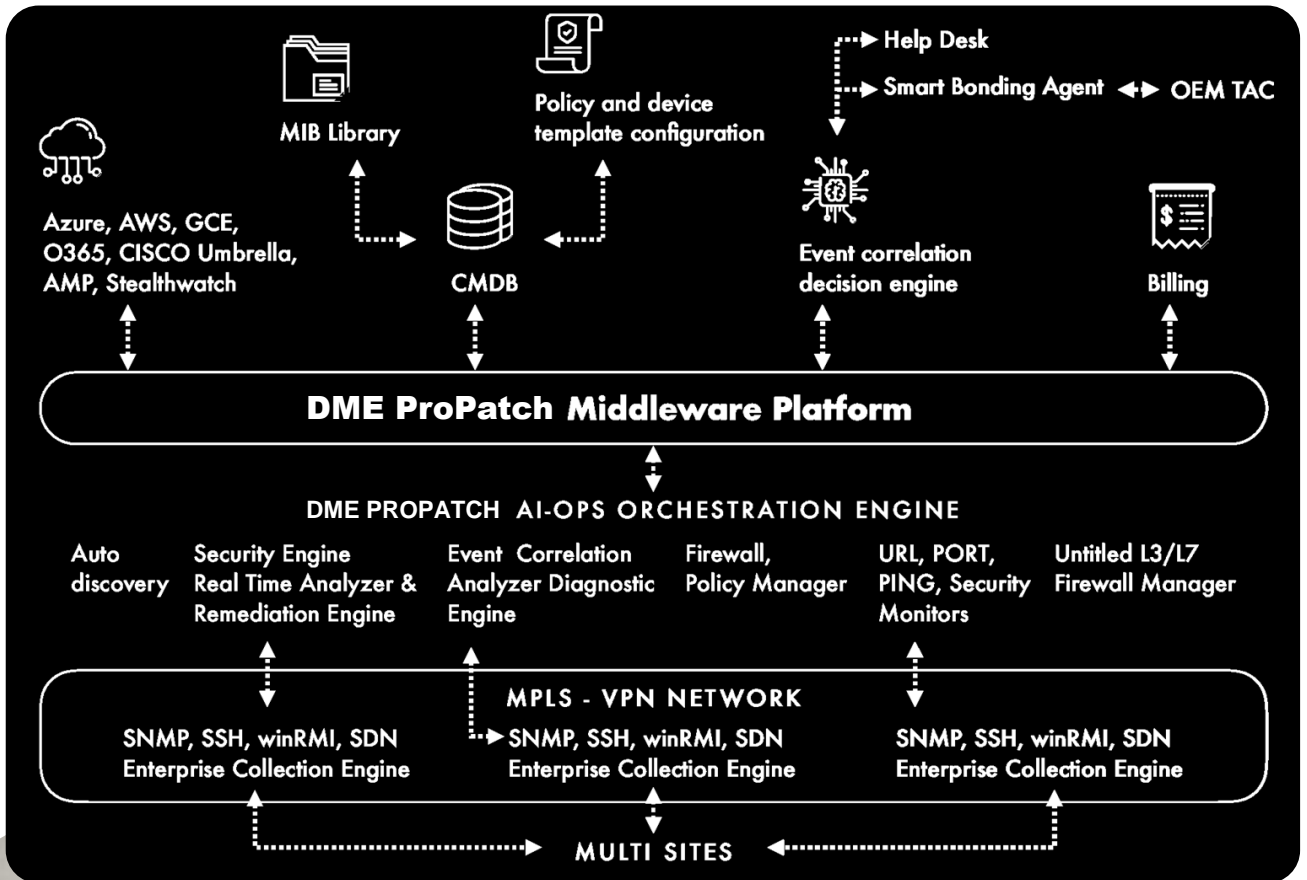

**Auto Thresholding**

**Application Performance Monitoring**

**Learning Engine**

**Auto Remediation**

**Database Service Monitoring**

**Storage**





## Key Features

Automatically discover the entire network using NMAP, CDP, FDP, LLDP, OSPF, BGP, SNMP and ARP

Supports NetFlow and sFlow for traffic analysis

Customizable Alerting – set thresholds for various counters and get alerted via Emails

Configuration backups

Automatic Updates & Device Pack updates and recommendations

Supports Active Directory (LDAP) based authentication Security Supports Amazon AWS, Google Cloud, Microsoft Azure and Office 365, WebEx Teams, Cisco Umbrella, Cisco Meraki via APIs and simple secret key based integration



Support for all critical functions

# DME ProPatch Intelligent Hardware

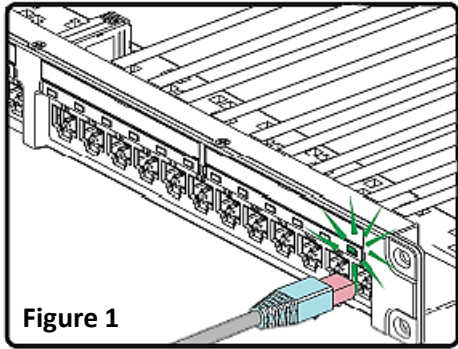

Figure 1

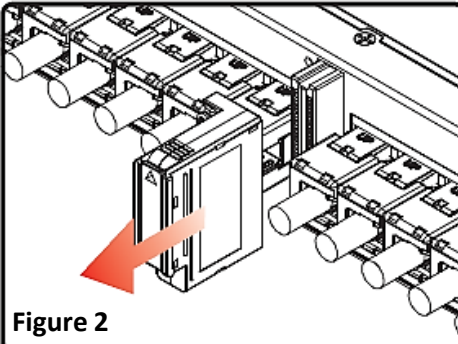

Figure 2

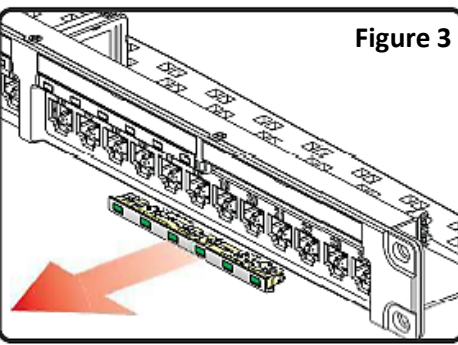

Figure 3

## Product Features

- DME ProPatch Copper Panels uses standard RJ45 Patch Leads (CAT5e, CAT6 and CAT6A) as shown on **Figure 1**. DME ProPatch Fiber Panel used standard LC or SC Fiber Patch cords
- With customizable software and LED indicator on DME ProPatch Panels, patching management become a very easy task.
- Any unauthorized activity will create a real time alert message.
- The complete DME ProPatch system is simple and modular. Each modules like MCU Modules (**Figure 2**) and LED modules (**Figure 3**) can be easily replaced without affecting the installed system.
- LED indicators with 2 colors - RED and GREEN
- DME ProPatch Fiber Panels can accommodate both LC-MPO and SC-MPO cassettes.
- AutoCAD file can be uploaded to the DME ProPatch software creating a Database for reference.
- Via Internet, through Webpage the cabling system can be monitored and controlled remotely.



LC MPO Cassette



SC MPO Cassette

## Specification

- Through each IP address it controls each Master MCU
- Each Master MCU can control 19 Slave MCU
- Power Supply: 5V/3A DC can support one rack panels
- Fiber LC-MPO Cassette Panel: 1U 48-Channel (96-Fiber)
- Fiber SC-MPO Cassette Panel: 1U 24-Channel (48-Fiber)
- Copper Patch Panel: 1U 24-Port

## Power Usage

Default Mode	Power Consumption	Annual Total Power Consumption
Mute	0.005W/Panel	0.05 KW.h /Panel
Running	0.1 W/Panel	0.9 KW.h /Panel
Light	0.135 W/Panel	1.2 KW.h /Panel

## DME ProPatch Intelligent Solution

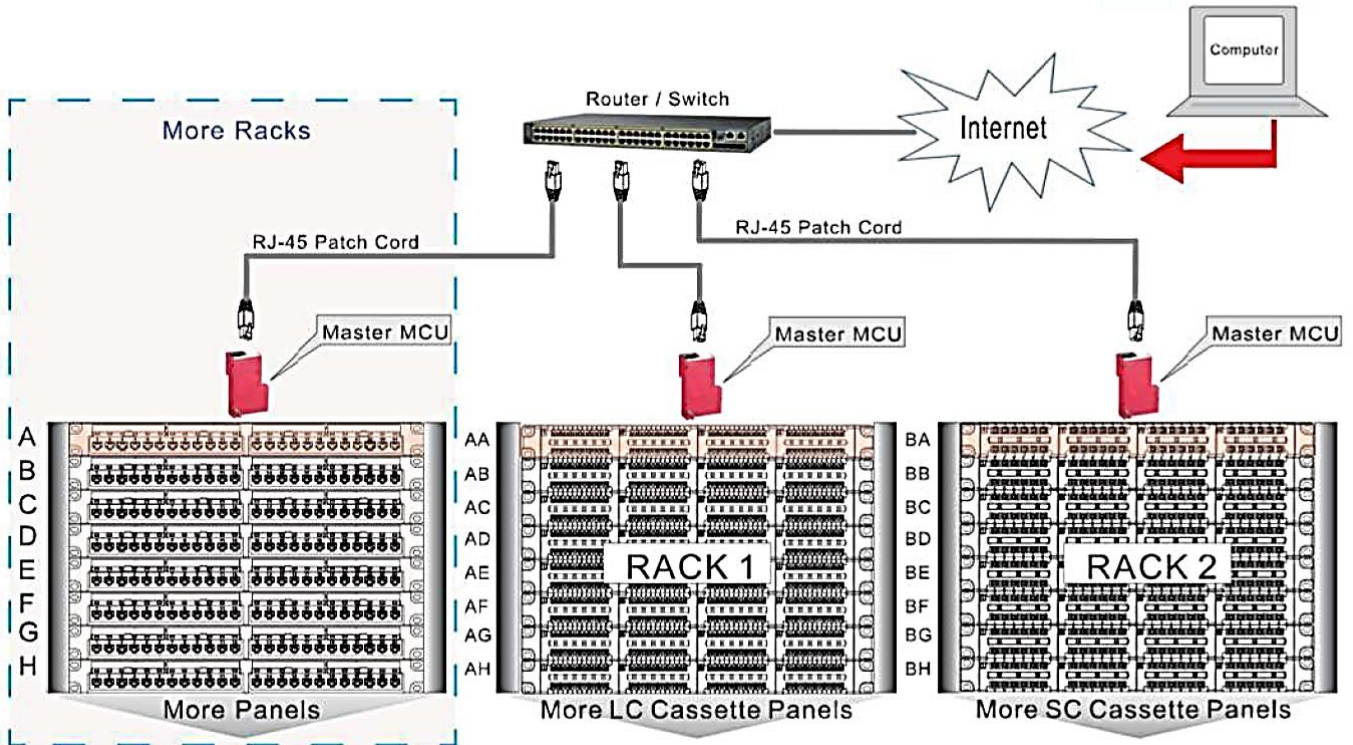

### Copper Patch Panels

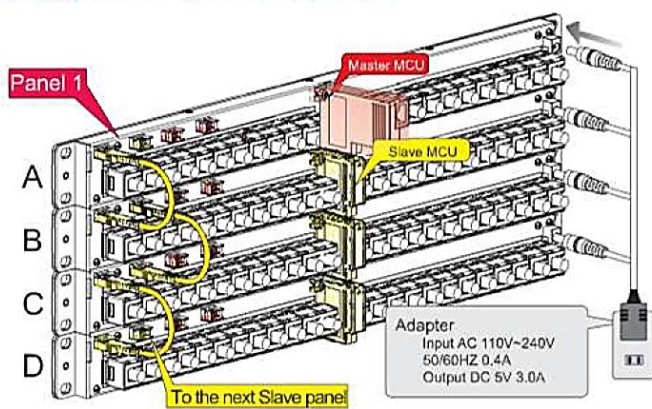

### LC & SC Cassette Panels

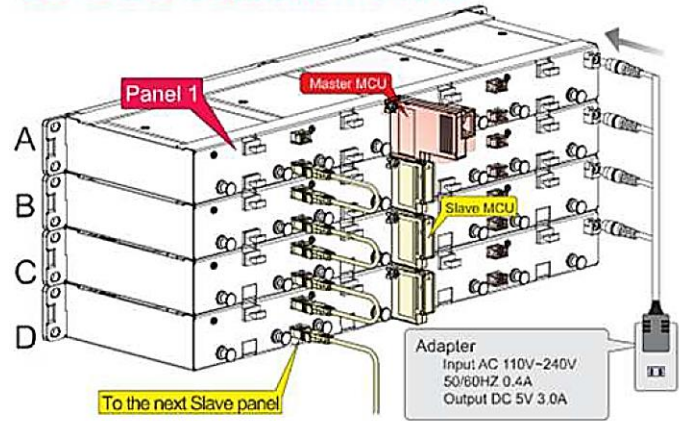



## DME ProPatch Support



The DME ProPatch intelligent monitoring system offers a single pane visibility to the network performance and a detailed report generation platform reducing the Opex considerably to the client's annual Networking budget. A comprehensive deployment and maintenance process is undertaken to ensure rapid and efficient implementation. The program includes development, deployment, training and remote support for a high-end user experience. Entire deployment and support procedures is in strict adherence with the regional DME ProLink Development Team.

## Warranty Aspects

All passive structured cabling components which is integral part of DME ProPatch solution qualifies for DME PROLINK 25 Years System Warranty and Applications Assurance.

The Active components which includes Intelligent Copper and Fiber Patch Panels, Intelligent FO Cassettes are covered under Three Year DME PROLINK Intelligent Components Product Warranty.



# DME ProPatch Intelligent Solution

## Part Number

D943-G241SHFULBK	DME ProPatch Intelligent Copper Patch Panel, 24 Port, 1RU, Shielded, Flush, Unloaded, Black (With Green LED Indicator)
D943-C6ASHFE	DME ProPatch Special Keystone Jack, shielded, CAT6A, Flush-mount, E-Tool Compatible, 90Deg
D943-GFEM1ULBK	DME ProPatch Intelligent Fiber Patch Panel, 1RU, Black (With Green LED Indicator)
D943-FCLC24AQ	DME ProPatch Intelligent Fiber Cassette LC, 24 Ports
D943-FCSC124GR	DME ProPatch Intelligent Fiber Cassette SC, 12 Ports
D943-MMCU	DME ProPatch Master Monitoring Control Unit (MCU) Module, with Ethernet Port, Red
D943-SMCU	DME ProPatch Slave Monitoring Control Unit (MCU) Module, Yellow
D943-C5E1YW	DME ProPatch CAT5e 1Pr Patch Cord, Yellow
D943-9PPWRC 1.3	DME ProPatch Power Cord 9 Pairs Out to Single Input 1.3M
D943-APWR1.2UK	DME ProPatch Power Adapter, Input 240VAC, Output: 5V / 3A
D943-DMEPROSW2	DME ProPatch Intelligent Software Version G (6.1) with 3 Years License
D9422-NTPROSW423	DME ProPatch Intelligent Infrastructure Management Stand Alone Limited Software Version 4.0 (2000 Ports 3 Years)
D9422-NTPROSW453	DME ProPatch Intelligent Infrastructure Management Stand Alone Limited Software Version 4.0 (5000 Ports 3 Years)

