

DME PROLINK 2 Post Open Racks

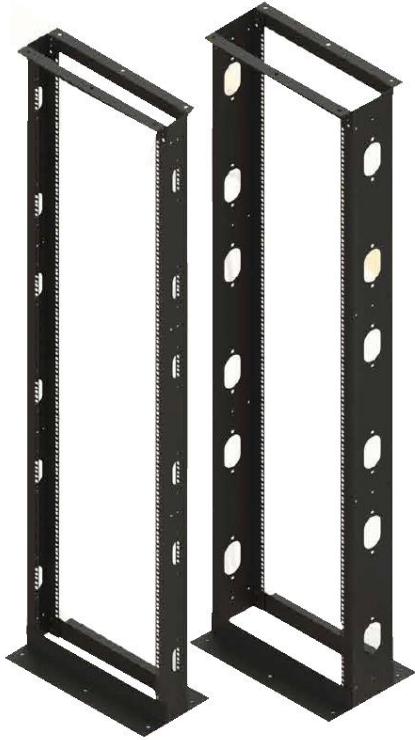

Description

DME PROLINK's 2 Post Open Frame Rack provides rack-mount solution for various IT environments and responding needs of High-density cable routing and telecom equipment installation.

Most important feature is optimized cooling and accessibility to the installed network equipments, each post frames equipped with Universal square holes for IT equipments, Switches, router, Server devices and all 19" telecommunication infrastructure components for today's communication technologies. This 2 post open frames are compatible with Levelling feet and casters usage.

Vertical cable manager can be placed at Left/Right for single open frame (Vertical cable manager should be ordered separately as an accessories). It's a well-engineered open rack system that offers you a high level of versatility and flexibility for routing high density cable bundles.

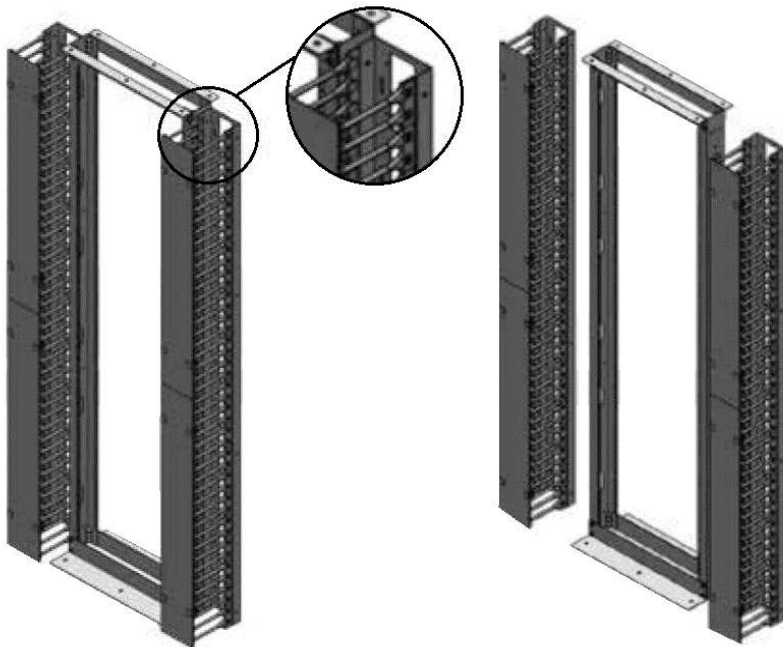

Features & Benefits

- Unobstructed airflow
- Easy Access
- Size range is 26U, 36U, 42U, 47U
- 19" Mounting Frame
- Sturdy construction 2mm thickness post
- L shaped bottom floor kit 3mm
- Standard Colors RAL 9005 (Black) & RAL 7035 (Grey)
- One Year Limited Product Warranty

Our Open Racks are manufactured with respect to International quality standards TSE-ISO-EN 9001-20018, TSE EN-61587-1:2012, EN 62208 and CE-2006/95/EC Low Voltage Directive 004/108/EC Electromagnetic Compatibility Directive

DME PROLINK 2 Post Open Racks – 540mm x 260mm



Isometric View

Explode View

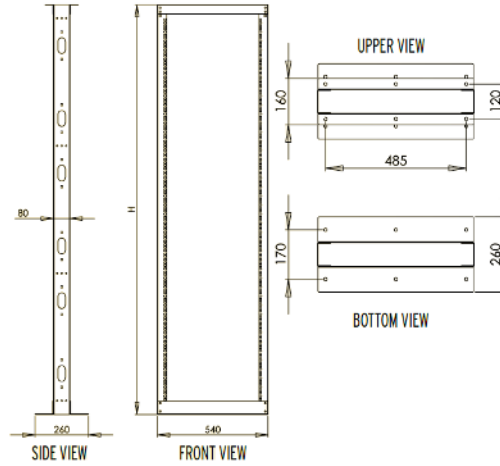

SIDE VIEW

FRONT VIEW

UPPER VIEW

BOTTOM VIEW

Part Number	Product Description	Height (mm)	Width (mm)	Depth (mm)
D3619-2ORK265426	2 Post Open Rack 26U 540mm x 260mm	1290	540	260
D3619-2ORK325426	2 Post Open Rack 32U 540mm x 260mm	1735	540	260
D3619-2ORK425426	2 Post Open Rack 42U 540mm x 260mm	2000	540	260
D3619-2ORK475426	2 Post Open Rack 47U 540mm x 260mm	2225	540	260

DME PROLINK 2 Post Open Racks – 540mm x 340mm



Isometric View

Explode View

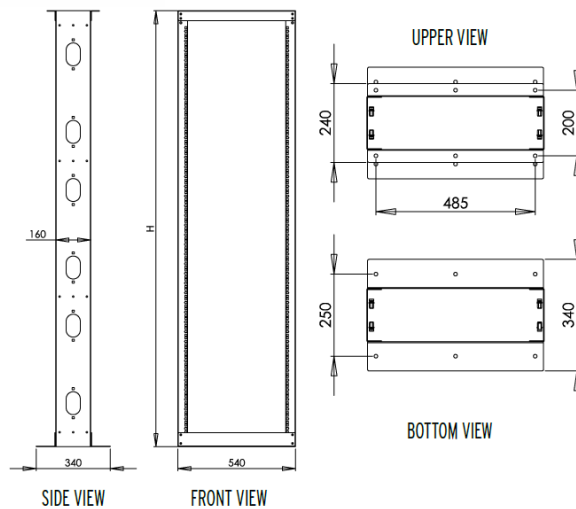

SIDE VIEW

FRONT VIEW

UPPER VIEW

BOTTOM VIEW

Part Number	Product Description	Height (mm)	Width (mm)	Depth (mm)
D3619-2ORK265434	2 Post Open Rack 26U 540mm x 340mm	1290	540	340
D3619-2ORK325434	2 Post Open Rack 32U 540mm x 340mm	1735	540	340
D3619-2ORK425434	2 Post Open Rack 42U 540mm x 340mm	2000	540	340
D3619-2ORK475434	2 Post Open Rack 47U 540mm x 340mm	2225	540	340

DME PROLINK 2 Post Open Rack Accessories

Vertical Cable Manager

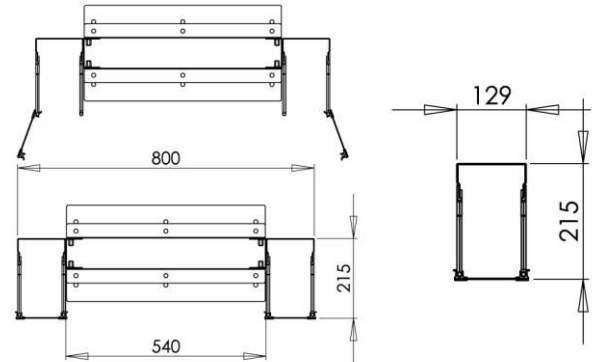
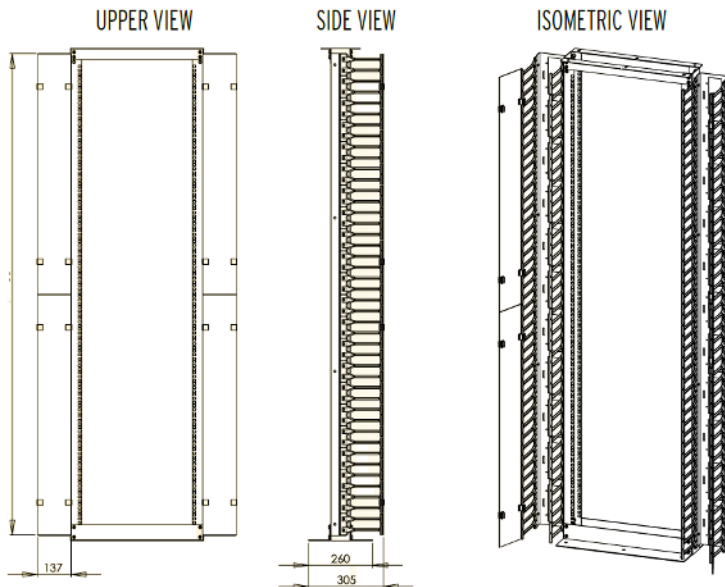

High density vertical cable manager equipped with plastic fingers for a comfortable bundle routing.

Part Number	Product Description	Height (mm)	Width (mm)	Depth (mm)
D3619-VCM261221	Vertical Cable Manager 26U 129mm x 215mm	1285	129	215
D3619-VCM321221	Vertical Cable Manager 32U 129mm x 215mm	1730	129	215
D3619-VCM421221	Vertical Cable Manager 42U 129mm x 215mm	1995	129	215
D3619-VCM471221	Vertical Cable Manager 47U 129mm x 215mm	2220	129	215

Castors & Leveling Feet

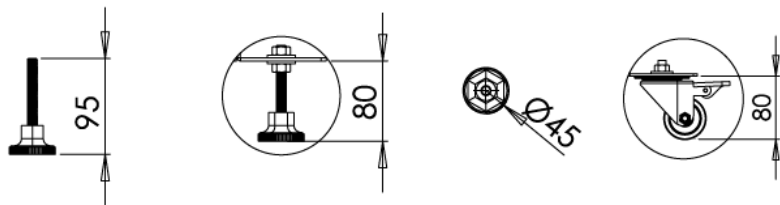

3mm thickness L-Shape floor kit is suitable for Caster and Leveling feet use.

Part Number	Product Description	Height (mm)	Width (mm)	Depth (mm)
D3619-C80809022	One Set - 2 Pcs Castors with brake & 2 Pcs Castors without brake. 360° Rotatable. Loading Capacity 150Kg	80	80	90
D3619-4LF9545	Leveling Feet (Metal/PVC). Loading capacity 250Kg - 4 Pcs	95	45	-